

Specification	AXLCM601A	Rev.:1	Date: 2020-10-24
---------------	-----------	--------	------------------

Type : Langasite Crystal Microbalance Element (Monitor Crystal)
for High Temperature applications

Parameter	min.	typ.	max.	Unit	Condition
Nominal frequency	6.000			MHz	
Crystal cut	Y ± 0.1°				
Overtone	1				
Adjustment tolerance			±15	kHz	@ 25°C
Frequency stability					
over temperature		-0.06		ppm/K ²	T ₀ ca. 20°C
Resonance resistance R _r			20	Ω	
Motional capacitance C ₁		200		fF	
Shunt capacitance C ₀			30	pF	
Drive level		100		μW	
Operable temperature range	0		+500	°C	
Storage temperature range	-40		+550	°C	
QCM diameter	13.97 +0/-0.01			mm	
Contour	Plano-convex				
Blank surface quality	Lapped				Ra = 0.05 ~ 0.2 μm
Electrode diameter Side A	13.0			mm	Fully plated
Electrode material Side A	Cr-Au				
Electrode diameter Side B	6.4			mm	Double anchor
Electrode material Side B	Cr-Au				

Side A (plano)

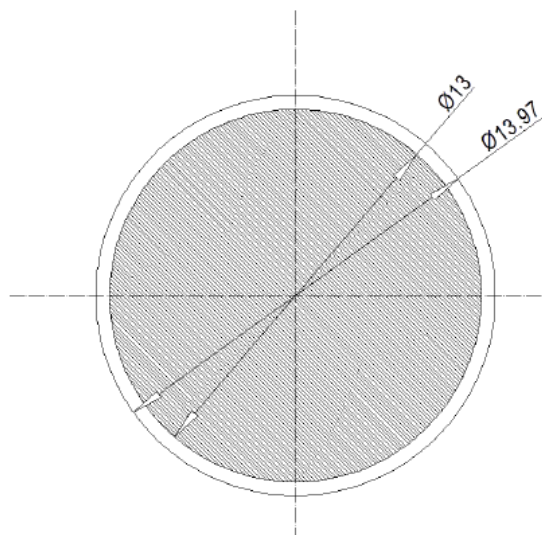

Side B (convex)

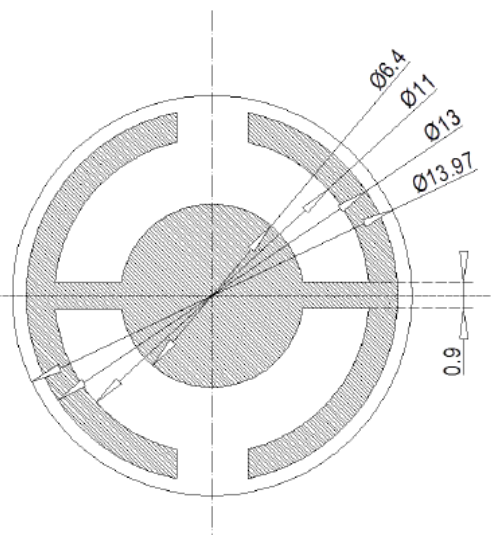

Ordering Code:

Model (Specification)	Revision	Frequency [MHz]
AXLCM601A	1	6.000

Revision History

Rev.	Drawing	Date [dd.mm.yyyy]	Remarks	Author	Checked
1	D0	204.10.2020	First issue AXQCM601A	BN	BN