

Specification	AXQCM501	Rev.: 1	Date: 2020-09-27
---------------	----------	---------	------------------

Quartz Crystal Microbalance Element (Monitor Crystal)



Parameter	min.	typ.	max.	Unit	Condition
Nominal frequency	5.000			MHz	
Adjustment frequency	4.960			MHz	AXQCM501A
	4.967			MHz	AXQCM501B
Crystal cut	AT				35°15'±1'
Overtone	1				
Frequency tolerance	-7		+7	kHz	
Frequency stability					
Over operating temperature range	-50		+50	ppm	
Resonance resistance R _r				15	Ω
Motional capacitance C ₁					fF
Shunt capacitance C ₀				20	pF
Drive level	100			μW	
Operating temperature range	+60	+70	+80	°C	
Storage temperature range	-40		+105	°C	
QCM diameter	13.97 +0/-0.03			mm	Plano-convex
Convex radius R	210			mm	
Blank surface quality	Fine lapped				R _a = 0.8 ~ 1.6 μm
Electrode diameter Side A	13.0 ± 0.1			mm	Fully plated
Electrode material Side A	Cr-Au				
Electrode diameter Side B	6.4			mm	See drawing
Electrode material Side B	Cr-Au				

Side A (Plane)

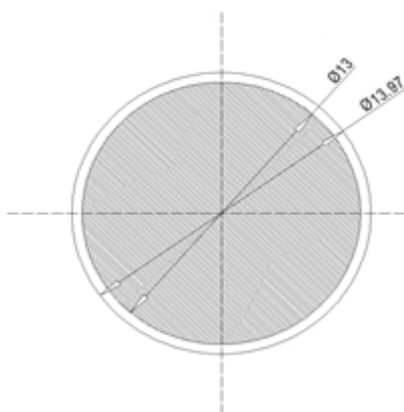

Side B (Convex)

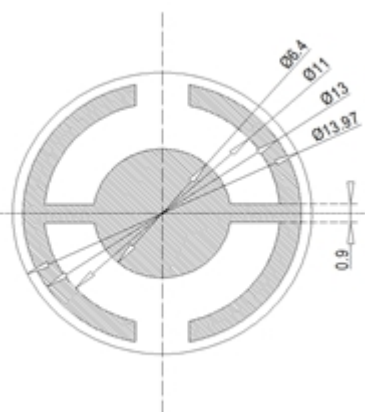

Ordering Code:

Model (Specification)	Revision	Frequency [MHz]
AXQCM501A	1	4.967
AXQCM501B	1	4.960

Revision History

Rev.	Drawing	Date [dd.mm.yyyy]	Remarks	Author	Checked
1	D0	27.09.2020	First issue AXQCM501	BN	BN