

Specification	AXGCM5600-240-Pt	Rev.:1	Date: 2018-12-21
---------------	------------------	--------	------------------

Type : **GaPO₄ - Crystal Microbalance Element (Monitor Crystal)**
For High Temperature Applications up to 850°C

Parameter	min.	typ.	max.	Unit	Condition
Nominal frequency	5.800			MHz	
Crystal cut	Y-12.5°				
Overtone	1				
Adjustment tolerance	-100		+100	kHz	
Frequency vs. temperature					See chart page 2
Turn-over temperature T ₀		+240		°C	
First order temperature coefficient		0.00717		ppm/K	ref. to T ₀
Second order temperature coefficient		-0.00976		ppm/K ²	ref. to T ₀
Third order temperature coefficient		7.2·10 ⁻⁶		ppm/K ³	ref. to T ₀
Mass sensitivity		0.3		ng/Hz	
Resonance resistance R _r			10	Ω	
Motional capacitance C ₁		80		fF	
Shunt capacitance C ₀		32		pF	
Drive level		100		μW	
Operating temperature range	0		+70	°C	
Storage temperature range	-40		+105	°C	
QCM diameter	13.97 ± 0.03			mm	
Blank surface quality	Fine lapped				
Contour	Planoconvex R= 265mm				
Electrode diameter Side A (plano)	13.0 ± 0.1			mm	Fully plated
Electrode material Side A	Pt (1000 nm)				No adhesion layer
Electrode diameter Side B (convex)	6.0			mm	See drawing
Electrode material Side B	Pt (1000 nm)				No adhesion layer
Maximum operating temperature			900	°C	

Side A (Plane)

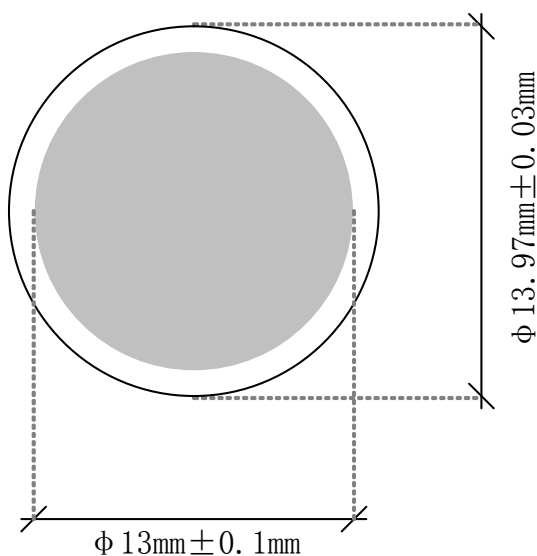

Side B (Convex)

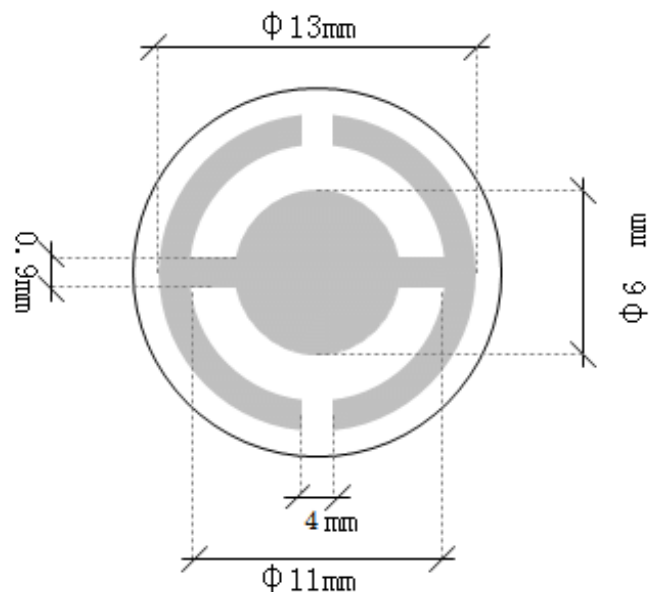

Frequency vs. temperature response characteristics

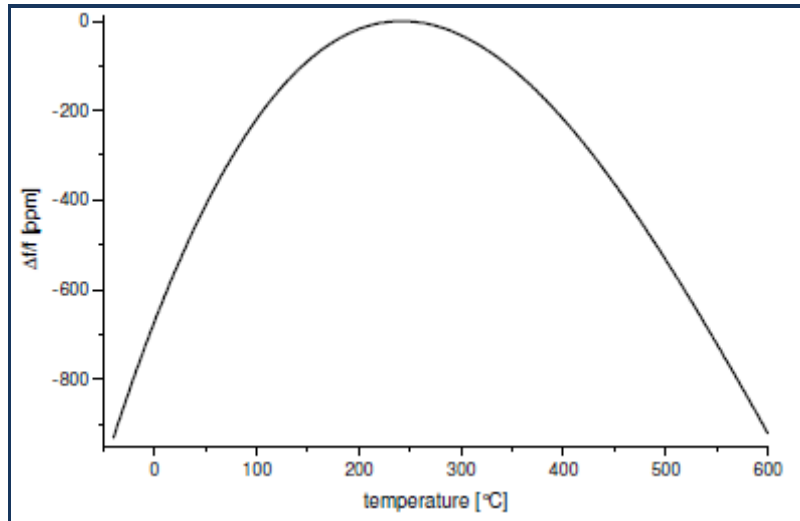

Ordering Code:

Model (Specification)	Revision	Frequency [MHz]
AXQCM5600-240-PT	Rev.1	5.600

Revision History

Rev.	Date [dd.mm.yyyy]	Remarks	Author	Checked
1	12.02.2014	First issue AXGCM5800-240-Au	BN	BN
1	21.12.2018	New version AXGCM5600-240-Pt with Pt electrodes for higher temperatures	BN	BN