

Specification	AXPX37	Rev.: 1	Date: 2018-02-28
----------------------	---------------	---------	------------------

Type: Precision Crystal Unit in Coldweld package HC-35/U

CROVEN CRYSTALS has provided high quality and reliability products to the frequency control industry for more than fifty years and is a world leader in the development and manufacture of the highest precision quartz resonators for demanding applications.

The HC-37 series of crystal resonators provides a broad range of frequencies and designs in a rugged, high reliability enclosure.

Features:

- cold weld sealed for low aging and low phase noise applications
- available in low g-sensitivity design configurations
- available in AT, SC and IT-cut designs
- RoHS compatible (if required)

Applications:

- precision OCXO, VCXO and TCXO oscillators
- military and high reliability applications

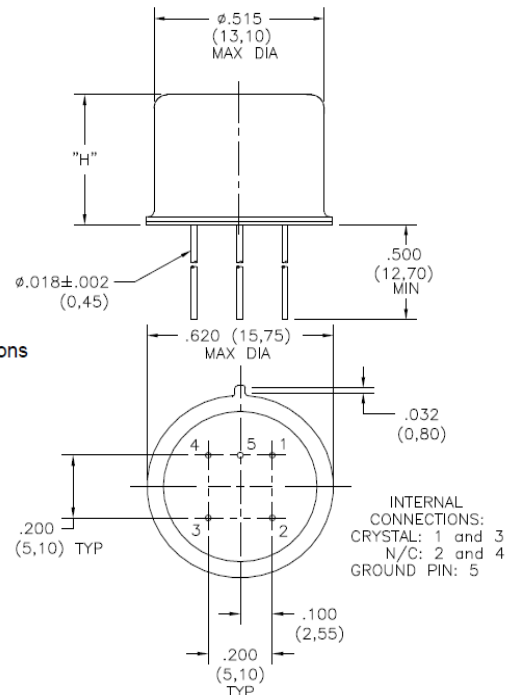

PARAMETER	Height 'H'	Mode	MINIMUM	MAXIMUM	UNITS
Resonant Frequency range @ specified load conditions and temperature	0.265" (6,73mm)	Fund	2.5	25	MHz
		3rd OT	5	60	
		5th OT	10	100	
	0.235" (5,95mm)	Fund	2.5	25	
		3rd OT	5	60	
		5th OT	10	100	
	0.160" (4,06mm)	Fund	2.5	25	
		3rd OT	10	60	
		5th OT	10	100	
Operating Temperature Range			- 55	+ 125	° C

PARAMETER	STANDARD METHOD OBSERVED
Shock	MIL-STD-202 Method 213, Condition C - 100 g, 6 msec 1/2 sine
Vibration	MIL-STD-202 Method 214, Condition C, 10 g peak 55-2000 Hz
Solderability	MIL-STD-202 Method 208
Workmanship	per the general requirements of MIL-PRF-3098

Notes:

- 1) Consult the factory for more detailed specifications or alternate requirements.

Revision History

Rev.	Drawing	Date [dd.mm.yyyy]	Remarks	Author	Checked
00		Jan 2009	Data sheet HC-37	Croven	Croven
1	D0	28.02.2018	First issue AXPX37	BN	BN