

Specification	AXLE208	Rev.: 2	Date: 2014-11-27
----------------------	----------------	---------	------------------

Oscillator type: (VC)TCXO in CO15 package

Parameter	min.	typ.	max.	Unit	Condition
Frequency range	6		190	MHz	Clipped Sine wave
	6		190	MHz	Sine wave
	1		800	MHz	HCMOS
Frequency stability				ppm	
vs. operating temperature range	±0.5 to ±5 See tables 1 & 2			ppm	Option 4 & 5
vs. supply voltage variation		±0.1	±0.3	ppm	V _S ±5 %
vs. load change			±0.2	ppm	Load ±10 %
Long term (aging) per year			±1	ppm	@+40°C
Frequency adjustment range					
Mechanical (internal trimmer)	±3			ppm	Option 1 = blank
Electronic Frequency Control (EFC)	±5			ppm	Option 1 = "V"
EFC voltage V _C	0.15	1.65	3.15	V	Option 2 = "3"
	0.5	2.5	4.5	V	Option 2 = "5"
EFC slope (Δf / ΔV _C)	Positive				
EFC input impedance	100			kΩ	
RF output					
Signal waveform	Clipped Sine wave Sine wave HCMOS				Option 3 = "C" Option 3 = "S" Option 3 = "H"
Load	10 kΩ 10 pF 50 Ω 15 pF				Option 3 = "C" Option 3 = "S" Option 3 = "H"
Amplitude	0.8			V p-p	Option 3 = "C" / 3.3 V
	1.0			V p-p	Option 3 = "C" / 5.0 V
		0		dBm	Option 3 = "S" / 3.3 V
		+3	+5	dBm	Option 3 = "S" / 5.0 V
	According to relevant Logic Standard				Option 3 = "H"
Supply voltage V_S	3.15	3.3	3.45	V	Option 2 = "3"
	4.75	5.0	5.25	V	Option 2 = "5"
Current consumption (Note 2)	2 ~ 30			mA	Option 3 = "C"
	12 ~ 30			mA	Option 3 = "S"
	15 ~ 50			mA	Option 3 = "H"
Enclosure (see drawing) (LxWxH)	20.3x20.3x5.3 max.			mm	IEC 60679-3 CO 15
Weight			8	g	
Packing	Palette				IEC 60286-3

Notes:

1. Terminology and test conditions are according to IEC60679-1 and MIL-PRF-55310, unless otherwise stated
2. Depending on frequency and supply voltage
3. All combinations of options might not be available. Please consult factory

Absolute Maximum Ratings

Parameter	min.	max.	Unit	Condition
Supply Voltage V_S	-0.5	$V_S + 10\%$	V	V_S to GND
Control Voltage V_C	-0.5	6	V	V_C to GND
Storage Temperature	-55	+105	°C	

Frequency stability vs. temperature

Option 4	Stability [ppm]
05	±0.5
10	±1.0
15	±1.5
20	±2.0
25	±2.5
30	±3.0
35	±3.5
50	±5.0

Table 1

Lower Temperature		Upper Temperature	
Option 5	T [°C]	Option 5	T [°C]
0	0	A	+50
1	-10	B	+60
2	-20	C	+70
3	-30	D	+75
4	-40	E	+80
		F	+85

Table 2

Ordering Code

Model	Option 1 [EFC]*	Option 2 [Supply Voltage]	Option 3 [RF output]	Option 4 [Stability]	Option 5 [Temperature range]	Revision	Frequency [MHz]
AXLE208	_ or "V"	3 or 5	C, S, H	Table 1	Table 2	Rev.2	10.000

Example: AXLE208-V-5-S-10-3D_Rev.2 – 10.000 MHz

Handling and Testing

Parameter	Procedure		Source
Handling and Testing	Application Note AXAN-011		www.axtal.com
Processing	Application Note AXAN-012		www.axtal.com
Parameter	Procedure		Condition
Electrostatic discharge (ESD)			
THD devices	IEC60749-26	HBM	2000 V
SMD devices	IEC60749-27	MM	200 V
Washable	<input type="checkbox"/> Yes <input checked="" type="checkbox"/> No		
RoHS compliant	<input checked="" type="checkbox"/> Yes <input type="checkbox"/> No		

Enclosure drawing

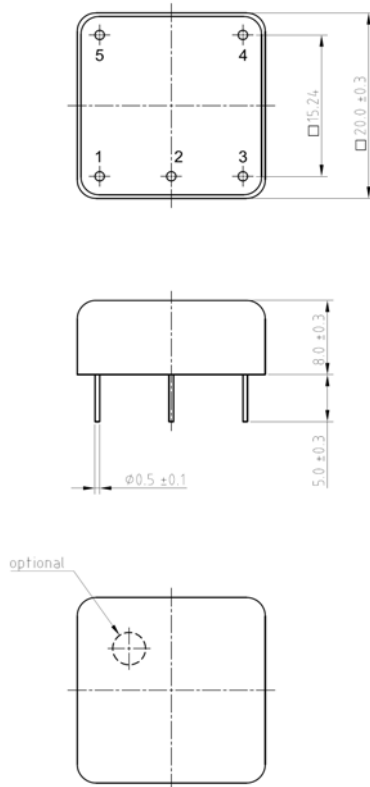

Pin connections

Pin #	Symbol	Function
1	N.C. or V_C	No Connection or Control Voltage (EFC)
2	RF OUT	RF Output
3	V_S	Supply Voltage
4	GND	Ground
5	GND	Ground

Environmental conditions

Test	IEC 60068 Part ...	IEC 60679-1 Clause	MIL-STD-202G Method	MIL-STD-810F Method	MIL-PRF-55310D Clause	Test conditions (IEC)
Sealing tests (if applicable)	2-17	5.6.2	112E		3.6.1.2	Gross leak: Test Qc, Fine leak: Test Qk
Solderability Resistance to soldering heat	2-20 2-58	5.6.3	208H 210F		3.6.52 3.6.48	Test Ta Method 1 Test Td ₁ Method 2 Test Td ₂ Method 2
Shock*	2-27	5.6.8	213B	516.4	3.6.40	Test Ea, 3 x per axes 100g, 6 ms half-sine pulse
Vibration, sinusoidal*	2-6	5.6.7.1	201A 204D	516.4-4	3.6.38.1 3.6.38.2	Test Fc, 30 min per axes, 10 Hz - 55 Hz 0,75mm; 55 Hz - 2 kHz, 10g
Vibration, random*	2-64	5.6.7.3	214A	514.5	3.6.38.3 3.6.38.4	Test Fdb
Endurance tests - ageing - extended aging		5.7.1 5.7.2	108A		4.8.35	30 days @ 85°C, OCXO @25°C 1000h, 2000h, 8000h @85°C

Other environmental conditions on request

Data sheet is for information purposes only and may be subject to modifications or may be discontinued without notice.

Revision History

Rev.	Drawing	Date [dd.mm.yyyy]	Remarks	Author	Checked
2	D0	22.09.2009	Editorial changes	BN	BN
2	D1	06.04.2014	Environmental conditions updated, editorial changes	HH	HH
2	D2	27.11.2014	Sine wave output level changed to +3 dBm typ.	BN	BN