

Specification	AXIOM5050	Rev.: 5	Date: 2019-08-19
----------------------	------------------	---------	------------------

Oscillator type: Ultra-Low Phase Noise OCXO in Connectorized Package

Parameter	min.	typ.	max.	Unit	Condition
Frequency range	50		160	MHz	
Standard frequencies	100.000 / 120.000			MHz	
Frequency stability					
Initial tolerance @ +25°C			±300	ppb	@ V _C = 5.0 V
vs. operating temperature range	Option 2 & 3 See tables 2 & 3				steady state
vs. supply voltage variation (pushing)			±10	ppb	V _S ±5%
vs. load change (pulling)			±5	ppb	R _L ±5%
Long term (aging) per day		±1	±2	ppb	after 30 days operation
Long term (aging) 1 st year		±100	±200	ppb	after 30 days operation
Frequency adjustment range					
Electronic Frequency Control (EFC)	±1	±2		ppm	
EFC voltage V _C	0	5.0	10.0	V	
EFC slope (Δf / ΔV _C)	Positive				
EFC input impedance	100			kΩ	
RF output					
Signal waveform	Sine wave				
Load R _L	50			Ω	±5%
Output level (Note 2)	+7	+12		dBm	
Harmonics			-30	dBc	
Spurious			-90	dBc	
Warm-up time @ +25°C		3	5	min	Δf _{final} /f ₀ < ±0.1 ppm
Phase noise	See table 1				Option 1
Supply voltage V_S (Note 3)	11.4	12.0	12.6	V	
Current consumption (steady state)			250	mA	@ +25°C
Current consumption (warm-up)			450	mA	
Enclosure (see drawing) (LxWxH)	50.0x50.0x21.0 max.			mm	
Weight			60	g	
Packing	Palette				

Notes:

1. Terminology and test conditions are according to IEC60679-1 and MIL-PRF-55310, unless otherwise stated
2. Other output level on request
3. Other supply voltage on request

Absolute Maximum Ratings

Parameter	min.	max.	Unit	Condition
Supply Voltage V _S	-0.5	V _S + 10%	V	V _S to GND
Control Voltage V _C	-0.5	15	V	V _C to GND
Storage Temperature	-55	+105	°C	

Phase Noise – Option 1:

Offset	50~110 MHz					>110~160 MHz					Unit
	A	B	C	D	E	A	B	C	D	E	
10 Hz	-90	-95	-100	-103	-105	-85	-90	-95	-97	-100	dBc/Hz
100 Hz	-120	-125	-130	-135	-137	-115	-120	-125	-127	-130	dBc/Hz
1 kHz	-150	-155	-160	-162	-164	-147	-150	-153	-155	-157	dBc/Hz
10 kHz	-170	-170	-170	-172	-174	-170	-170	-170	-170	-172	dBc/Hz
≥100 kHz	-175	-175	-175	-175	-175	-175	-175	-175	-175	-175	dBc/Hz

Table 1

Note: Other phase noise parameters on request

Frequency stability vs. temperature

Option 2	Stability
	[ppb]
25	±25
50	±50
100	±100
200	±200

Table 2

Lower Temperature		Upper Temperature	
Option 3	T [°C]	Option 3	T [°C]
0	0	A	+50
1	-10	B	+60
2	-20	C	+70
3	-30	D	+75
4	-40	E	+80
5	-55	F	+85

Table 3

Standard: "1B" = -10°C to +60°C

Temperature range [°C]	Frequency stability [Option 2]			
	25	50	100	200
0 ~ +50	X	X	X	X
-10 ~ +60	X	X	X	X
-20 ~ +70	X	X	X	X
-30 ~ +70	X	X	X	X
-40 ~ +75	O	X	X	X
-40 ~ +85	-	O	X	X
-55 ~ +85	-	-	O	X

Table 4 "Availability" X = available, O = available on request, - not available

Ordering Code

Model	Option 1 [Phase noise]	Option 2 [Stability]	Option 3 [Temperature range]	Revision	Frequency [MHz]
AXIOM5050	Table 1	Table 2	Table 3	Rev.5	100.000

Example: AXIOM5050-C-50-1B_Rev.5 – 100.000 MHz

Enclosure drawing

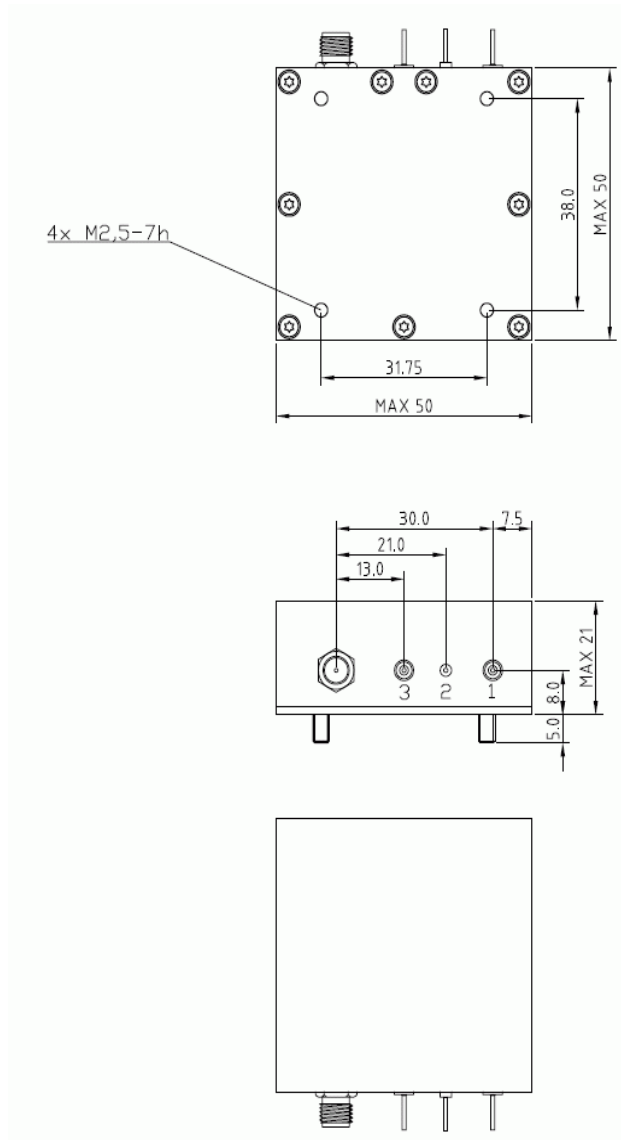

Pin connections:

Pin #	Symbol	Function
1	V _s	Supply Voltage
2	GND	Ground
3	V _c	Control Voltage (EFC)
SMA	RF OUT	RF Output

Handling and Testing

Parameter	Procedure		Source
Handling and Testing	Application Note AXAN-011		www.axtal.com
Processing	Application Note AXAN-012		www.axtal.com
Parameter	Procedure		Condition
Electrostatic discharge (ESD)			
THD devices	IEC60749-26	HBM	2000 V
SMD devices	IEC60749-27	MM	200 V
Washable	<input checked="" type="checkbox"/> Yes <input type="checkbox"/> No		
RoHS- Compliant	<input checked="" type="checkbox"/> Yes <input type="checkbox"/> No		

Environmental conditions

Test	IEC 60068 Part ...	IEC 60679-1 Clause	MIL-STD-202G Method	MIL-STD-810F Method	MIL-PRF-55310D Clause	Test conditions (IEC)
Sealing tests (if applicable)	2-17	5.6.2	112E		3.6.1.2	Gross leak: Test Qc, Fine leak: Test Qk
Solderability Resistance to soldering heat	2-20 2-58	5.6.3	208H 210F		3.6.52 3.6.48	Test Ta Method 1 Test Td ₁ Method 2 Test Td ₂ Method 2
Shock	2-27	5.6.8	213B	516.4	3.6.40	Test Ea, 3 x per axes 100g, 6 ms half-sine pulse
Vibration, sinusoidal	2-6	5.6.7.1	201A 204D	516.4-4	3.6.38.1 3.6.38.2	Test Fc, 30 min per axes, 10 Hz - 55 Hz 0,75mm; 55 Hz - 2 kHz, 10g
Vibration, random	2-64	5.6.7.3	214A	514.5	3.6.38.3 3.6.38.4	Test Fdb
Endurance tests - ageing - extended aging		5.7.1 5.7.2	108A		4.8.35	30 days @ 85°C, OCXO @25°C 1000h, 2000h, 8000h @85°C

Other environmental conditions on request

Data sheet is for information purposes only and may be subject to modifications or may be discontinued without notice.

Revision History

Rev.	Drawing	Date [dd.mm.yyyy]	Remarks	Author	Checked
3	D0	14.10.2013	Major revision	CG	BN
4	D0	26.04.2014	Frequency range extended, various parameters updated, environmental conditions updated, editorial changes	HH	HH
5	D0	19.08.2019	Frequency range extended, phase noise & stability options updated, editorial changes	HH	HH