

Specification	AXIOM90	Rev.: 4	Date: 2014-04-18
----------------------	----------------	---------	------------------

Oscillator type: OCXO with Sine Wave Output and SMA Connector

Parameter	min.	typ.	max.	Unit	Condition
Frequency range	10		40	MHz	
Standard frequencies	10.000/20.000/30.000			MHz	
Frequency stability					
Initial tolerance @ +25°C			±300	ppb	V _c @ centre value
vs. operating temperature range	Option 2 & 3 See tables 1 & 2				steady state
vs. supply voltage variation (pushing)			±10	ppb	V _s ±5%
vs. load change (pulling)			±10	ppb	R _L ±10%
Long term (aging) per day (after 30 days operation) (Note 2)			±10 ±2	ppb ppb	AT-Cut SC-Cut
Long term (aging) 1 st year (after 30 days operation) (Note 2)		±300 ±50	±500 ±200	ppb ppb	AT-Cut SC-Cut
Frequency adjustment range					
Electronic Frequency Control (EFC)	±2 ±0.8		±5	ppm ppm	AT-Cut SC-Cut
EFC voltage V _c	0.15 0.25	1.65 2.50	3.15 4.75	V V	Option 1 = "33" Option 1 = "50", "12"
EFC slope ($\Delta f / \Delta V_c$)	Positive				
EFC input impedance	100			kΩ	
RF output					
Signal waveform	Sine wave				
Load R _L	50			Ω	±10%
Output level (Note 3)	+3			dBm	
Harmonics			-30	dBc	
Spurious			-90	dBc	
Warm-up time @ +25°C		3	5	min	$\Delta f_{\text{final}}/f_0 < \pm 0.1$ ppm
Phase Noise					
Consult factory					
Supply voltage V_s	3.15	3.3	3.45	V	Option 1 = "33"
	4.75	5.0	5.25	V	Option 1 = "50"
	11.4	12.0	12.6	V	Option 1 = "12"
Current consumption (steady state) @ +25°C (Note 4)			350	mA	Option 1 = "33"
			250	mA	Option 1 = "50"
			150	mA	Option 1 = "12"
Current consumption (warm-up) (Note 4)			900	mA	Option 1 = "33"
			600	mA	Option 1 = "50"
			350	mA	Option 1 = "12"
Enclosure (see drawing) (LxWxH)	54.0x40.5x19.0 max.			mm	h = 2.0 mm
Weight			60	g	
Packing	Palette				

Notes:

1. Terminology and test conditions are according to IEC60679-1 and MIL-PRF-55310, unless otherwise stated
2. Lower aging on request
3. Other output level on request
4. May be higher for wide operating temperature range

Absolute Maximum Ratings

Parameter	min.	max.	Unit	Condition
Supply Voltage V_S	-0.5	$V_S + 10\%$	V	V_S to GND
Control Voltage V_C	-0.5	15	V	V_C to GND
Storage Temperature	-55	+125	°C	

Frequency stability vs. temperature

Option 2	Stability [ppb]
05	±5
10	±10
25	±25
50	±50
100	±100
200	±200

Table 1

Lower Temperature		Upper Temperature	
Option 3	T [°C]	Option 3	T [°C]
0	0	A	+50
1	-10	B	+60
2	-20	C	+70
3	-30	D	+75
4	-40	E	+80
5	-55	F	+85

Table 2

Standard: "1B" = -10°C to +60°C

Temperature range [°C]	Frequency stability [Option 2]					
	05	10	25	50	100	200
0 ~ +50	SC	SC	SC	AT	AT	AT
-10 ~ +60	SC	SC	SC	AT	AT	AT
-20 ~ +70	O	SC	SC	SC	AT	AT
-30 ~ +70	O	O	SC	SC	SC	AT
-40 ~ +75	O	O	SC	SC	SC	SC
-40 ~ +85	O	O	O	SC	SC	SC
-55 ~ +85	-	O	O	SC	SC	SC

Table 3 "Availability" AT, SC = AT-Cut, SC-Cut available, O = available on request, - not available

Ordering Code

Model	Option 1 [Supply Voltage]	Option 2 [Stability]	Option 3 [Temperature range]	Revision	Frequency [MHz]
AXIOM90	12, 33, 50	Table 1	Table 2	Rev.4	30.000

Example: AXIOM90-50-100-1B_Rev.4 – 30.000 MHz

Enclosure drawing

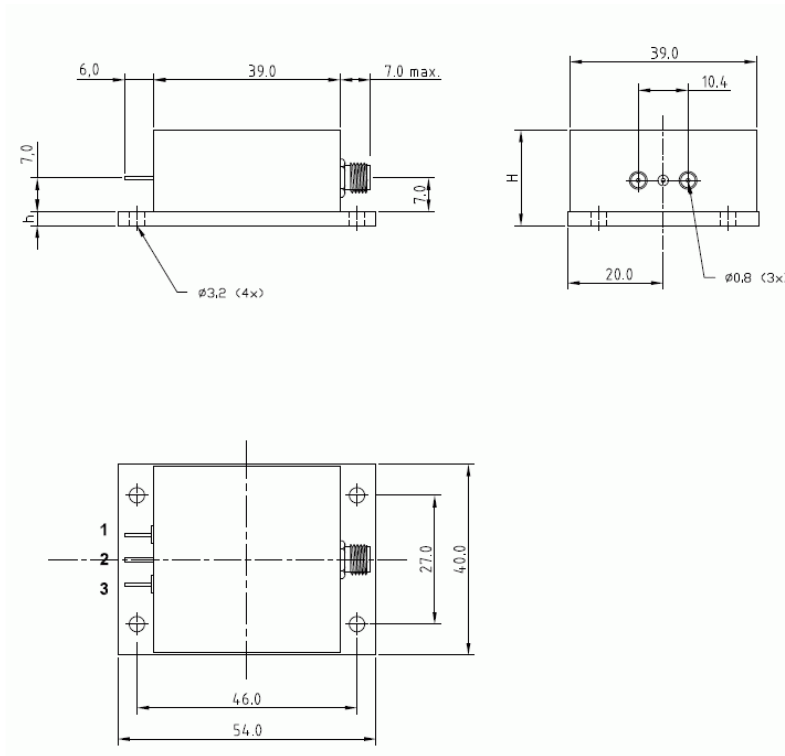

Pin connections

Pin#	Symbol	Function
1	V _C	Control Voltage (EFC)
2	GND	Ground
3	V _S	Supply Voltage
SMA	RF OUT	RF Output

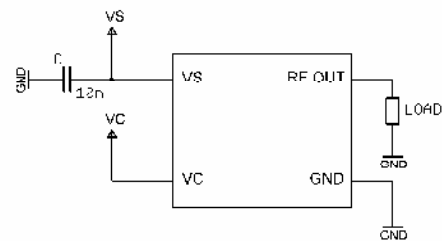

* See Application Note AXAN-011

Handling and Testing

Parameter	Procedure		Source
Handling and Testing	Application Note AXAN-011		www.axtal.com
Processing	Application Note AXAN-012		www.axtal.com
Parameter	Procedure		Condition
Electrostatic discharge (ESD)			
THD devices	IEC60749-26	HBM	2000 V
SMD devices	IEC60749-27	MM	200 V
Washable	✘ Yes <input type="checkbox"/> No		
RoHS- Compliant	✘ Yes <input type="checkbox"/> No		

Environmental conditions

Test	IEC 60068 Part ...	IEC 60679-1 Clause	MIL-STD-202G Method	MIL-STD-810F Method	MIL-PRF-55310D Clause	Test conditions (IEC)
Sealing tests (if applicable)	2-17	5.6.2	112E		3.6.1.2	Gross leak: Test Qc, Fine leak: Test Qk
Solderability	2-20	5.6.3	208H		3.6.52	Test Ta Method 1
Resistance to soldering heat	2-58		210F		3.6.48	Test Td ₁ Method 2 Test Td ₂ Method 2
Shock*	2-27	5.6.8	213B	516.4	3.6.40	Test Ea, 3 x per axes 100g, 6 ms half-sine pulse
Vibration, sinusoidal*	2-6	5.6.7.1	201A 204D	516.4-4	3.6.38.1 3.6.38.2	Test Fc, 30 min per axes, 10 Hz - 55 Hz 0,75mm; 55 Hz - 2 kHz, 10g
Vibration, random*	2-64	5.6.7.3	214A	514.5	3.6.38.3 3.6.38.4	Test Fdb
Endurance tests - ageing - extended aging		5.7.1 5.7.2	108A		4.8.35	30 days @ 85°C, OCXO @25°C 1000h, 2000h, 8000h @85°C

Other environmental conditions on request

Data sheet is for information purposes only and may be subject to modifications or may be discontinued without notice.

Revision History

Rev.	Drawing	Date [dd.mm.yyyy]	Remarks	Author	Checked
3	D0	14.10.2013	Extended ordering parameter list	CG	BN
4	D0	18.04.2014	Various parameters updated, environmental conditions updated, editorial changes	HH	HH