

| | | | |
|----------------------|--------------------|-----------|-----------------|
| Specification | AXLE3225GPS | Issue: 01 | Date:2010-08-05 |
|----------------------|--------------------|-----------|-----------------|

Oscillator type : Hi-Stability TCXO in SMD package

| Parameter | min. | typ. | max. | Unit | Condition |
|--|-----------------------------|------|-------|--------|----------------------|
| Standard frequencies | 16.369 / 16.367667 | | | MHz | Note 2 |
| Frequency stability | | | | ppm | |
| Initial tolerance, after twice reflow | | | ± 2 | ppm | @25°C |
| vs. operating temperature range | | | ± 0.5 | ppm | |
| Operating temperature range | -30 | | +85 | °C | |
| Frequency slope | | | ± 0.1 | ppm/K | -20°C to +70°C |
| Frequency-temperature hysteresis | | | ± 0.6 | ppm | Quasi-static |
| vs. supply voltage variation | | | ± 0.2 | ppm | V _S ± 5 % |
| vs. load change | | | ± 0.2 | ppm | Load ± 10 % |
| long term (aging) per year | | | ± 1.0 | ppm | @+25°C |
| RF output | | | | | |
| Signal waveform | Clipped Sine wave | | | | |
| Load | 10 kΩ 10 pF | | | | ± 10 % |
| Amplitude (peak-peak) | 0.8 | 1.4 | 1.7 | V p-p | |
| Harmonics | | | -8 | dBc | |
| Phase noise | | | -50 | dBc/Hz | @ 1 Hz |
| | | | -80 | dBc/Hz | @ 10 Hz |
| | | | -105 | dBc/Hz | @ 100 Hz |
| | | | -125 | dBc/Hz | @ 1 kHz |
| | | | -140 | dBc/Hz | @ 10 kHz |
| Start-up time | | | 5 | ms | Δf/f < ± 2.5 ppm |
| Supply voltage V_S | 2.66 | 2.8 | 2.94 | V | |
| Current consumption | | | 1.5 | mA | |
| Storage temperature range | -45 | | +90 | °C | |
| Enclosure (see drawing) L x W x H | 3.4 x 2.7 x 1.2 max. | | | mm | 6-pad |
| Packing | Tape & reel | | | | |
| Handling and Testing | In accordance with AXAN-011 | | | | www.axtal.com |
| Processing | In accordance with AXAN-012 | | | | www.axtal.com |

Notes:

1. Terminology and test conditions are according to IEC standard IEC60679-1, unless otherwise stated
2. Other frequencies on request

Ordering Code:

| Part number | Frequency [MHz] |
|--------------------|-----------------|
| AXLE3225GPS | 16.369 |

Test Circuit:

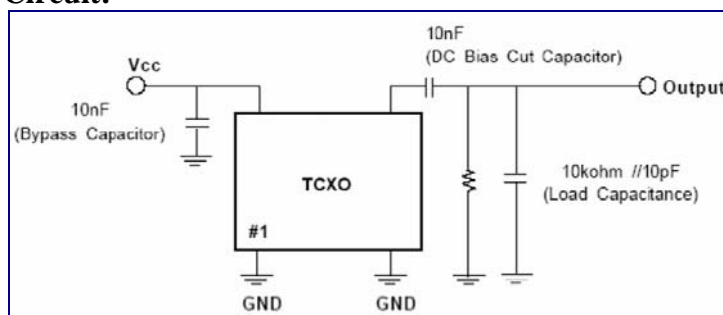

Enclosure drawing:

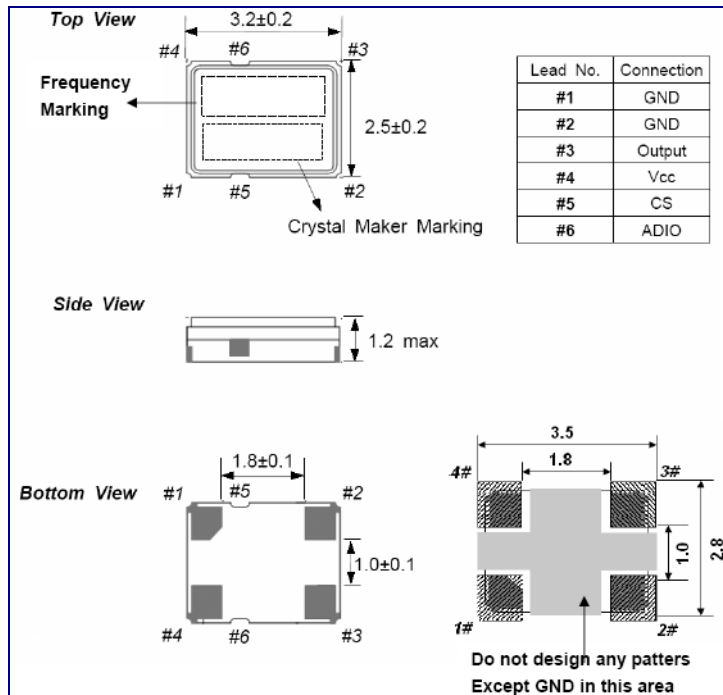

pins #5 and #6 not to be used externally

Environmental conditions:

| Test | IEC 60068 Part | IEC 60679 Part 1 Clause ... | Test conditions |
|--------------------------|----------------|-----------------------------|--|
| Solderability | 2-20 | 4.6.3 | Test Ta (235 ± 5)°C Method 1 Precond: 105°C, 100% RH 4 hr. |
| Free fall* | 2-32 | 4.6.9 | 150 cm onto concrete, each side (6), corner (1), total 7 drops |
| Vibration, random* | 2-6 | 4.6.8 | 20 Hz ~ 2 kHz 0.053 G ² /Hz, 15 min per each axis |
| Free fall* | 2-32 | 4.6.9 | Test Ed procedure 1, 2 drops from 1m height |
| High temperature storage | | | +85°C over 120 hours |
| Low temperature storage | | | -40°C over 120 hours |
| Humidity storage | | | +85°C, 85% RH over 240 hours |
| Thermal shock | | | -40°C ~ +85°C / 30 min. each, 100 cycles |
| Endurance tests | | | |
| - ageing | | 4.7.1 | 30 days @ 85°C |
| - extended aging* | | 4.7.2 | 1000h, 2000h, 8000h @ 85°C |

Other environmental conditions on request