

Specification	AXLE20	Issue: 04	Date: 2009-09-22
----------------------	---------------	-----------	------------------

Oscillator type : TCXO in SMD package

Parameter	min.	typ.	max.	Unit	Condition
Frequency range	9		33	MHz	
Standard frequencies	10 / 16.384 / 19.44			MHz	
Frequency stability				ppm	
Initial tolerance		± 1		ppm	@+25°C
vs. temperature in operating temperature range (steady state)	Frequency stability				Temperature
			± 2.5	ppm	-40°~+85°C
			± 1.5	ppm	-20°~+70°C
		± 0.8	ppm		0°~+50°C
vs. supply voltage variation			± 0.2	ppm	
vs. load change			± 0.2	ppm	
long term (aging) per year			± 1	ppm	@ +40°C
Frequency adjustment range					
Electronic Frequency Control (EFC)	± 5			ppm	
EFC voltage V_C	0.25		4.75	V	Option II = "50"
	0.30		3.0	V	Option II = "33"
EFC slope ($\Delta f / \Delta V_C$)	negative				
EFC linearity				%	
EFC input impedance	100			k Ω	
RF output					
Signal waveform	Clipped Sine wave				
Load	10 k Ω // 10 pF				
Amplitude	0.8			V	peak-to-peak
Start-up time			4	ms	
Phase noise @ 16.384 MHz		-85		dBc	10 Hz
		-115		dBc	100 Hz
		-130		dBc	1000 Hz
		-145		dBc	10000 Hz
Supply voltage V_S	4.75	5.0	5.25	V	Option II = "50"
	3.13	3.3	3.47	V	Option II = "33"
Current consumption (steady state)			5	mA	@ +25°C
Operable temperature range	-45		+90	°C	
Storage temperature range	-45		+95	°C	
Enclosure (see drawing)	14.4x9.5x6 max			mm	IEC 61837 CO 30
Weight			5	gram	
Packing	Tape & reel				IEC 60286-3
ESD Sensitivity	1500			V	HBM as IEC 61000-4-2
Handling and Testing	In accordance with AXAN-011				www.axtal.com
Processing	In accordance with AXAN-012				www.axtal.com

Notes:

1. Terminology and test conditions are according to IEC standard IEC60679-1, unless otherwise stated
2. Overall frequency stability = initial tolerance + temp.stability + supply & load change + aging

Ordering Code:

Model (Specification)	Option I	Option II	Frequency [MHz]
AXLE20	25	33	12.800

Enclosure drawing

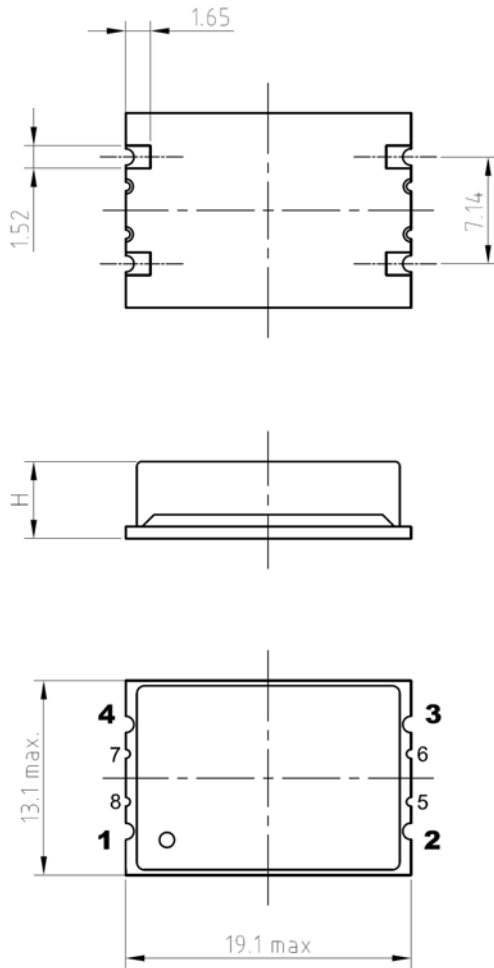

Pin connections

Pin #	Symbol	Function
1	V _C	Control Voltage (EFC)
2	GND	Ground
3	RF OUT	RF Output
4	V _S	Supply Voltage
5~8	I.C.	Do not connect

Environmental conditions

Test	IEC 60068 Part ...	IEC 60679-1 clause ...	Test conditions
Sealing tests (if applicable)	2-17	4.6.2	Gross leak: Test Qc, Fine leak: Test Qk
Solderability Resistance to soldering heat	2-20 2-58	4.6.3	Test Ta (235 ± 5)°C Method 1 Test Tb Method 1A, 5s
Shock*	2-27	4.6.8	Test Ea, 3 x per axes 100g, 6 ms half-sine pulse
Vibration, sinusoidal*	2-6	4.6.7	Test Fc, 30 min per axes, 10 Hz - 55 Hz 0,75mm; 55 Hz - 2 kHz, 10g
Endurance tests - ageing - extended aging		4.7.1 4.7.2	30 days @ 85°C, OCXO @25°C 1000h, 2000h, 8000h @85°C

Other environmental conditions on request