

<b>Specification</b>	<b>AXLE195</b>	Issue: 01	Date:2009-11-02
----------------------	----------------	-----------	-----------------

**Oscillator type : TCXO in SMD package**

Parameter	min.	typ.	max.	Unit	Condition
<b>Frequency range</b>	6 1		190 800	MHz MHz	(Clipped) Sine wave HCMOS
<b>Frequency stability</b>				ppm	
vs. temperature	± 0.5 ppm to ± 5 ppm			ppm	See tables 1 & 2
vs. supply voltage variation		± 0.1	± 0.3	ppm	
vs. load change			± 0.2	ppm	± 10 %
long term (aging) per year			± 1	ppm	@+40°C
<b>Frequency adjustment range</b>					
Mechanical (internal trimmer)	± 3			ppm	Option 1 = blank
Electronic Frequency Control (EFC)	± 5			ppm	Option 1 = "V"
EFC voltage $V_C$	0.15 0.5	1.65 2.5	3.15 4.5	V V	Option 2 = "3" Option 2 = "5"
EFC slope ( $\Delta f / \Delta V_C$ )	positive				
EFC input impedance	100			k $\Omega$	
<b>RF output</b>					
Signal waveform (Note 4)	Sine wave Clipped Sine wave HCMOS				Option 3 = "S" Option 3 = "C" Option 3 = "H"
Load	50 $\Omega$ 10 k $\Omega$    10 pF 15 pF				Option 3 = "S" Option 3 = "C" Option 3 = "H"
Amplitude	0.8 1.0	0 +10		dBm dBm V p-p V p-p	Option 3 = "S" / 3.3 V Option 3 = "S" / 5.0 V Option 3 = "C" / 3.3 V Option 3 = "C" / 5.0 V
	According to relevant Logic Standard				Option 3 = "H"
<b>Supply voltage <math>V_S</math></b>	3.15 4.75	3.3 5.0	3.45 5.25	V V	Option 2 = "3" Option 2 = "5"
<b>Current consumption</b> (Note 3)	12 ~ 100 2 ~ 30 15 ~ 100			mA mA mA	Option 3 = "S" Option 3 = "C" Option 3 = "H"
<b>Storage temperature range</b>	-45		+90	°C	
<b>Enclosure (see drawing) (L x W x H)</b>	20.3 x 13.0 x 5.7 max.			mm	Similar to IEC 61837 CO 30
<b>Packing</b>	Tape & reel				IEC 60286-3
<b>Handling and Testing</b>	In accordance with AXAN-011				www.axtal.com
<b>Processing</b>	In accordance with AXAN-012				www.axtal.com

**Notes:**

1. Terminology and test conditions are according to IEC standard IEC60679-1, unless otherwise stated
2. All combinations of options might not be available. Please consult factory
3. Depending on frequency and supply voltage and signal waveform
4. PECL and LVDS output on request (without EFC function)

## Frequency Stability over Temperature

Table 1

Code4	Stability
05	± 0.5
10	± 1.0
15	± 1.5
20	± 2.0
25	± 2.5
30	± 3.0
35	± 3.5
50	± 5.0

Table 2

Lower Temperature		Upper Temperature	
Code5	Temp/°C	Code5	Temp/°C
0	0	A	+50
1	-10	B	+60
2	-20	C	+70
3	-30	D	+75
4	-40	E	+80
		F	+85

### Ordering Code:

Part number	Option 1	Option 2	Option 3	Option 4	Option 5
	EFC	Supply Voltage	Output	Stability	Temp. range
<b>AXLE195</b>	_ or "V"	5 or 3	S, C, H	See tables 1 & 2	

Example: AXLE195-V-5-S-10-3D – 10.000 MHz

### Enclosure drawing

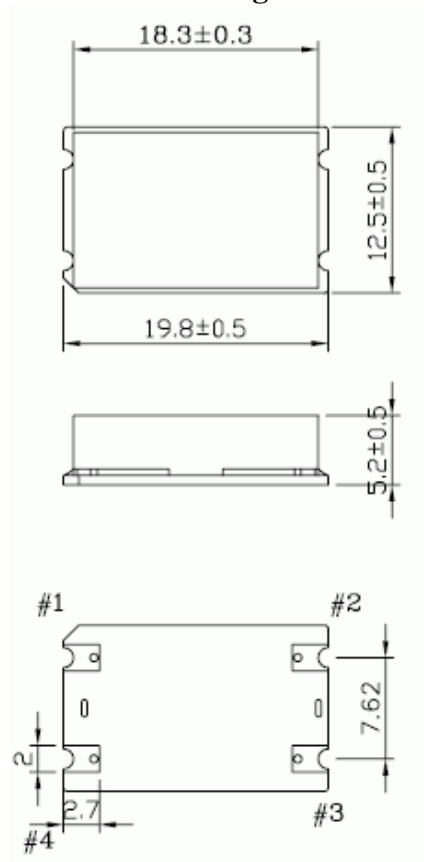

### Pin connections

Pin #	Symbol	Function
1	N.C. or VC	No Connection or Voltage Control (EFC)
2	GND	Ground
3	RF OUT	RF Output
4	Vs	Supply Voltage