

Specification	AXE20P	Issue: 02	Date: 2009-09-22
----------------------	---------------	-----------	------------------

Oscillator type : Programmable Crystal Oscillator in DIL14 package

Parameter	min.	typ.	max.	Unit	Condition
Frequency range	1		100	MHz	$V_S = 5\text{ V}$
	1		133	MHz	$V_S = 3.3\text{ V}$
Programmable frequencies	Any discrete frequency				At delivery
Frequency stability					
Overall stability			± 100 ± 50 ± 25	ppm ppm ppm	Option I = "100" Option I = "50" Option I = "25"
operating temperature range	0		+70	$^{\circ}\text{C}$	Option II = "A"
	-20		+70	$^{\circ}\text{C}$	Option II = "B"
	-40		+85	$^{\circ}\text{C}$	Option II = "C"
long term (aging)			± 5	ppm/year	@ 40°C
RF output					
Signal waveform	HCMOS				
Load	15			pF	
Rise & decay time			5	ns	
Symmetry (duty cycle)	40		60	%	@ $V_S/2$
Start-up time			10	ms	
RMS Jitter			50	ps	Freq $\leq 33\text{ MHz}$
			40	ps	Freq $> 33\text{ MHz}$ (3.3V)
			30	ps	Freq $> 33\text{ MHz}$ (5V)
Supply voltage V_S	3.15	3.3	3.45	V	Option III = "33"
	4.75	5.0	5.25		Option III = "50"
Current consumption (steady state) Note 2			45	mA	Option III = "33"
			25	mA	Option III = "50"
Operable temperature range	-45		+90	$^{\circ}\text{C}$	
Storage temperature range	-55		+125	$^{\circ}\text{C}$	
Enclosure (see drawing)	20.7x13.1x5.5 max.			mm	IEC 60679-3 CO-02
Weight			5	gram	
Packing	Palette or tube				IEC 60286-3
ESD Sensitivity	1500			V	HBM, IEC 61000-4-2
Handling and Testing	In accordance with AXAN-011				www.axtal.com
Processing	In accordance with AXAN-012				www.axtal.com

Notes:

1. Terminology and test conditions are according to IEC standard IEC60679-1, unless otherwise stated
2. Current consumption depends on frequency

Ordering Code:

Model (Specification)	Option I	Option II	Option III	Frequency [MHz]
AXE20P	100	A	50	12.345678

Enclosure drawing

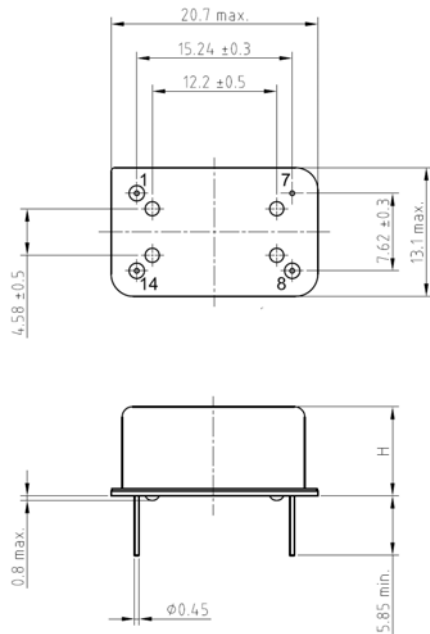

Pin connections

Pin #	Symbol	Function
1	N.C.	Not connected
7	GND	Ground
8	RF OUT	RF Output
14	Vs	Supply Voltage

Environmental conditions

Test	IEC 60068 Part ...	IEC 60679-1 clause ...	Test conditions
Sealing tests (if applicable)	2-17	4.6.2	Gross leak: Test Qc, Fine leak: Test Qk
Solderability Resistance to soldering heat	2-20 2-58	4.6.3	Test Ta (235 ± 5)°C Method 1 Test Tb Method 1A, 5s
Shock*	2-27	4.6.8	Test Ea, 3 x per axes 100g, 6 ms half-sine pulse
Vibration, sinusoidal*	2-6	4.6.7	Test Fc, 30 min per axes, 10 Hz - 55 Hz 0,75mm; 55 Hz - 2 kHz, 10g
Endurance tests - ageing - extended aging		4.7.1 4.7.2	30 days @ 85°C, OCXO @25°C 1000h, 2000h, 8000h @85°C

Other environmental conditions on request