

Specification	AXON1000	Rev.: 1	Date: 2016-08-19
----------------------	-----------------	---------	------------------

Oscillator type: UHF Low Noise Phase-Locked Oscillator (PLO)

Parameter	min.	typ.	max.	Unit	Condition
Reference frequency (input) f_{REF}	10		150	MHz	
Output frequency f_{OUT}	300		3000	MHz	
Frequency stability (free running)					
frequency tolerance			±20	MHz	
vs. operating temperature range		±10	±20	MHz	
Reference input					
Frequency accuracy			±10	ppm	
Signal waveform	Sine wave				
Input level	+0		+13	dBm	
Input impedance	50			Ω	
RF output					
Signal waveform	Sine wave				
Load R_L	50			Ω	±5%
Output level	+7	+10		dBm	
Harmonics			-30	dBc	
Spurious			-80	dBc	
PLL Products			-60	dBc	
Phase noise (Note 2)	Consult factory				
Lock detect (LD) output		0	1.5	V	Out of lock
	3.5	5		V	Locked
Supply voltage V_S	11.4	12.0	12.6	V	
Current consumption		100	150	mA	
Operating temperature range	-20		+70	°C	
Enclosure (see drawing) (LxWxH)	54x40x19			mm	h = 2.0
Weight		60		g	
Packing	Palette				

Notes:

1. Terminology and test conditions are according to IEC60679-1 and MIL-PRF-55310, unless otherwise stated
2. PLL will be optimized to application w.r.t. phase noise

Absolute Maximum Ratings

Parameter	min.	max.	Unit	Condition
Supply Voltage V_S	-0.5	$V_S + 10\%$	V	V_S to GND
Reference Input Level	-	+15	dBm	
Storage Temperature	-55	+105	°C	

Ordering Code

Model	Input Frequency [MHz]	Output Frequency [MHz]	Revision
AXON1000	100	1000	Rev.1

Example: AXON1000-100-1000_Rev.1

Enclosure drawing

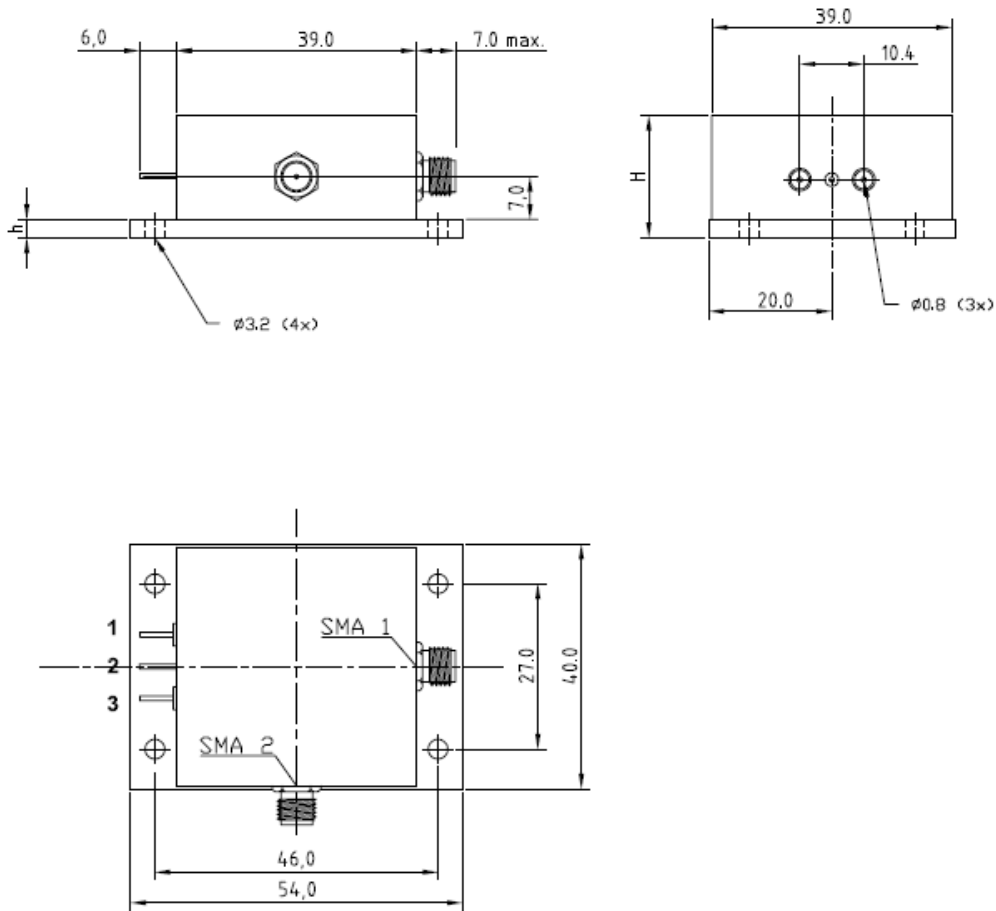

Pin connections:

Pin #	Symbol	Function
1	LD	Lock Detect Output
2	GND	Ground
3	V _s	Supply Voltage
SMA1	RF OUT	RF Output
SMA2	FREF	Reference Frequency Input

Handling and Testing

Parameter	Procedure		Source
Handling and Testing	Application Note AXAN-011		www.axtal.com
Processing	Application Note AXAN-012		www.axtal.com
Parameter	Procedure		Condition
Electrostatic discharge (ESD)			
THD devices	IEC60749-26	HBM	2000 V
SMD devices	IEC60749-27	MM	200 V
Washable	<input checked="" type="checkbox"/> Yes <input type="checkbox"/> No		
RoHS- Compliant	<input checked="" type="checkbox"/> Yes <input type="checkbox"/> No		

Environmental conditions

Test	IEC 60068 Part ...	IEC 60679-1 Clause	MIL-STD-202G Method	MIL-STD-810F Method	MIL-PRF-55310D Clause	Test conditions (IEC)
Sealing tests (if applicable)	2-17	5.6.2	112E		3.6.1.2	Gross leak: Test Qc, Fine leak: Test Qk
Solderability Resistance to soldering heat	2-20 2-58	5.6.3	208H 210F		3.6.52 3.6.48	Test Ta Method 1 Test Td ₁ Method 2 Test Td ₂ Method 2
Shock*	2-27	5.6.8	213B	516.4	3.6.40	Test Ea, 3 x per axes 100g, 6 ms half-sine pulse
Vibration, sinusoidal*	2-6	5.6.7.1	201A 204D	516.4-4	3.6.38.1 3.6.38.2	Test Fc, 30 min per axes, 10 Hz - 55 Hz 0,75mm; 55 Hz - 2 kHz, 10g
Vibration, random*	2-64	5.6.7.3	214A	514.5	3.6.38.3 3.6.38.4	Test Fdb
Endurance tests - ageing - extended aging		5.7.1 5.7.2	108A		4.8.35	30 days @ 85°C, OCXO @25°C 1000h, 2000h, 8000h @85°C

Other environmental conditions on request

Data sheet is for information purposes only and may be subject to modifications or may be discontinued without notice.

Revision History

Rev.	Drawing	Date [dd.mm.yyyy]	Remarks	Author	Checked
1	D0	19.08.2016	First issue	HH	HH